

TRION®

Indoor Air Quality

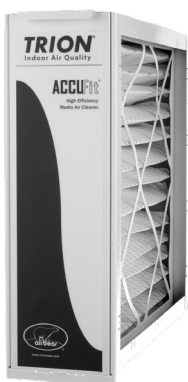

READ AND SAVE THESE INSTRUCTIONS

UNITS NOT FOR COMMERCIAL USE

Air Bear® Accu-Fit™

Media Air Cleaner

Table of Contents

Introduction	1
Unit Selection Guide	2
Installation	3
Maintenance	6
Warranty	7

Your media air cleaner is a high efficiency air filtration device designed to remove dirt, dust, pollen, and other microscopic particles from the air passing through it.

How the Air Cleaner Works

Dirty air enters the air cleaner by way of the return air duct system in your home. Particles are collected by the special pleated filter media. The pleats provide an exceptionally large filtering face area in a very compact space which allows maximum dirt holding capacities with minimum air flow resistance.

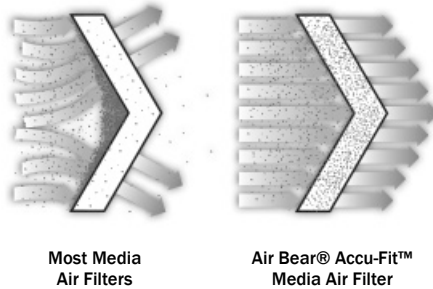

Air Handlers

Use with electric forced warm air furnaces and with compressor cooling. Can be used with heat pumps if filter is changed regularly to prevent excessive pressure drop. Not recommended for applications where pressure drop may be critical.

Gas Furnaces

Use with gas, oil, and electric forced warm air furnaces and with compressor cooling. Can be used with heat pumps if filter is changed regularly to prevent excessive pressure drop. Not recommended for applications where pressure drop may be critical.

Specifications

Air Bear® Accu-Fit™ Media Air Cleaners include cabinet, access door, and pleated MERV 8 media filter.

Efficiency: Ratings are based on ASHRAE Standard 52.2-2012. MERV at 492 fpm.

Temperature Rating: -40°F to 140°F (-40°C to 60°C)

Mounting: Mounts in any position in the return air duct, usually next to the furnace blower compartment. Cabinet is sturdy enough to support weight of a residential furnace and evaporator coil.

Unit Selection Guide

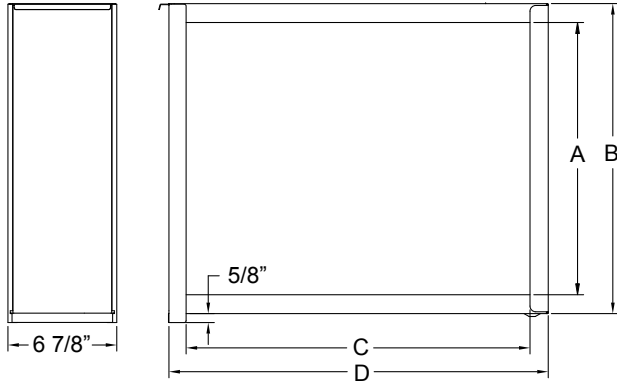

Unit	Air Handlers				Gas Furnaces	
	17 ½ x 21	21 x 21	24 ½ x 21	17 ½ x 28	21 x 28	24 ½ x 28
Part No.	267645-52117	267645-52121	267645-52124	267645-52817	267645-52821	267645-52824
Capacity	1400 CFM	1800 CFM	2000 CFM	1800 CFM	2000 CFM	2000 CFM

Cabinet Outside Dimensions in Inches (Reference Drawing Above)						
Dim A	15.00	18.50	22.00	15.00	18.50	22.03
Dim B	17.50	21.06	24.50	17.50	21.06	24.50
Dim C	18.69	18.69	18.69	25.69	25.63	25.69
Dim D	21.00	21.00	21.00	28.00	28.00	28.00

Cabinet Duct Opening Dimensions						
Height	15.02	18.58	22.02	16.25	19.81	23.25
Width	18.67	18.67	18.67	26.20	26.20	26.20

Typical Mounting Positions

(Air cleaner shown shaded in illustrations)

WARNING

Before making changes to a HVAC system that may affect the ventilation of fuel-burning appliances, contact your heating contractor.

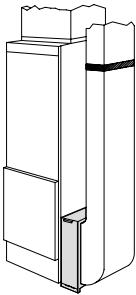

Highboy furnace, with side installation. Media air filter is mounted vertically where return enters side inlet of furnace.

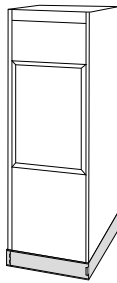

Highboy furnace, with installation beneath furnace. Media air cleaner is mounted horizontally where return enters from below.

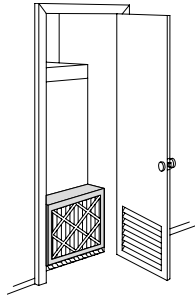

Highboy furnace, with closet installation. Media air cleaner is mounted vertically on furnace between furnace and louvered return air opening in closet door.

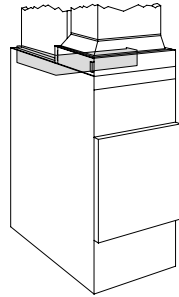

Lowboy furnace, with media air cleaner mounted horizontally in return plenum just above furnace and opposite heating plenum.

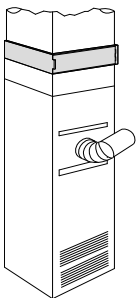

Counterflow furnace, with media air cleaner mounted horizontally in return duct or plenum just above furnace.

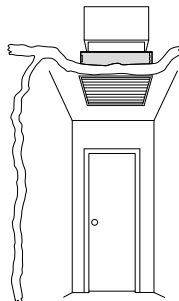

Central fan installation, with media air cleaner mounted horizontally in central return duct.

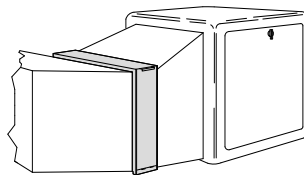

Horizontal furnace, with media filter mounted vertically in return duct near furnace.

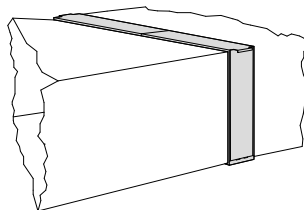

Two or more media air cleaners used in a high capacity system.

Installation

Installation Requirements

The Air Bear® Accu-Fit™ media air cleaner should be installed where all the air passing through the system is circulated through it. Maximum performance is obtained with the system blower set for continuous operation.

The best location for the air cleaner is in the return air duct next to the blower compartment. In this location, the blower motor and cooling coils will be kept clean. Do not install the air cleaner in the discharge air duct. Do not install the air cleaner directly exposed to UV lighting. Before installing the air cleaner, consider the application. If a transition between the ductwork and air cleaner is required, refer to section entitled **Transitions**, below.

The unit must be readily accessible for periodic inspection and replacement of the filter cartridge to maintain maximum efficiency and trouble-free operation. A clean coil will reduce utility costs by maintaining the coil's efficiency. Failure to replace filter cartridge can cause damage to the cooling system. Allow a minimum of 26" clearance in front of the access panel for filter cartridge replacement.

Applications with Air Conditioning

Mount the media air cleaner upstream of the evaporative coil in a cooling system. The filter will help keep the coil clean and reduce maintenance.

Applications with a Humidifier

The media air cleaner is compatible with humidifiers. Avoid applications where water mist will reach the media. If an atomizing humidifier is used, the filter media will require replacement more often because of minerals in the water.

Transitions

If the air duct does not fit the air cleaner cabinet opening, gradual transitions are recommended to reduce air turbulence through the air cleaner and maximize efficiency. Not more than 20° (about 4" per running foot) of expansion should be used on each side of the transition fitting. If the media air cleaner is installed next to an elbow or angle fitting, add turning vanes inside the angle to distribute airflow more evenly across the face of the media.

Install Turning Vanes

Install turning vanes to help distribute air equally over the full surface of the upstream side of the media. Install them whenever an abrupt 90° elbow is installed directly against the media air cleaner cabinet.

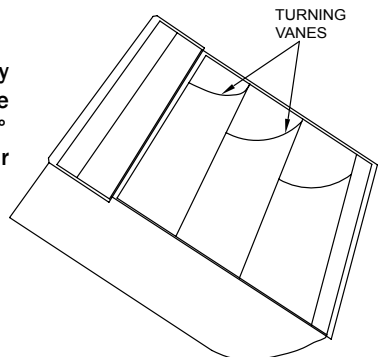

When Installing This Product...

1. Read these instructions carefully. Failure to follow them could damage the media air filter or cause a hazardous condition.
2. Check the ratings given in the instructions and on the media air cleaner to ensure the product is suitable for your application.
3. Installer must be a trained, experienced service technician.

Remove Filter and Clean Blower Compartment

Before starting the installation, remove and discard the existing filter (if used). Thoroughly clean the blower compartment. If possible, power vacuum the ductwork to remove accumulated dust in an occupied home or remove construction dirt in a new home. The media air cleaner cannot remove dirt that has settled in the blower compartment and distribution ducts.

Install the Cabinet

The following procedure describes a typical side installation on an existing highboy furnace. Alternate procedures are noted as appropriate. Other changes in installation procedures may be necessary to complete your installation.

Review the Installation Plan

Temporarily place the cabinet on the floor, oriented as it will be when installed. Insert and remove the cartridge to make sure the plan allows adequate clearance for easy removal and replacement of the cartridge. Make sure that shop-fabricated sheet metal components, such as turning vanes, are available.

Fasten the Cabinet to the Furnace

Align the cabinet with the return air opening. Place blocks under the cabinet, as necessary, to ensure the unit sits securely. Create an opening in the furnace to match the cabinet opening. Attach the cabinet securely to the furnace. Attach the unit directly or fit a starting collar in the furnace opening. Either drill holes and fasten with sheet metal screws or rivets, or use slip joints. If you are drilling holes, use a locking pliers to help hold the unit in place during drilling.

Fasten Cabinet to Ductwork

Fasten side of cabinet to the ductwork using sheet-metal screws, rivets, or slip joints, as appropriate.

Connect Ductwork

Connect the vertical duct section to the elbow. If the vertical drop of the duct is less than 7 in. (178 mm) from the side of the furnace, shorten the horizontal trunk or attach an offset fitting to the elbow. When ductwork is properly aligned, connect the vertical duct to the horizontal trunk.

Seal Joints

Seal all joints in the return air system between the media air filter and the furnace to prevent dust from entering the clean airstream.

Install Filter Cartridge

Slide the filter cartridge into the cabinet, making sure the arrow on the cartridge points in the direction of air flow. Replace access door. Insert the tab on the bottom of the door into the slot in the cabinet. Swing the door closed and press it into place.

Maintenance

Checkout

Visually check the installation. Make sure:

- Airflow is in the direction of the arrow on the media air filter cartridge.
- Turning vanes and transitions, if used, are properly installed.
- Joints in sheet metal between media air filter and furnace are sealed.
- All sheet metal connections are complete.
- Original furnace filter has been removed and blower compartment is cleaned.

Replace any access doors removed during the Installation or Checkout. Run the furnace or cooling system through one complete cycle to make sure the system operates as desired.

How to Maintain Your Air Cleaner

The media filter cartridge in your air cleaner must be replaced periodically. The frequency of filter replacement is best determined by visual examination. On average, MERV 8 filter cartridges with normal usage should be replaced every 9 - 12 months. Clogged media must be replaced promptly to avoid restricting airflow and reducing efficiency of the heating cooling system. Record the replacement date in the space provided on the replacement media filter. Contact your HVAC dealer for replacement filter cartridges.

Steps for Replacing Filter Cartridge

1. Open access door by pulling the handle. Remove door completely.
2. Pull used filter straight out of cabinet and place to side.
3. Remove new filter cartridge from plastic bag and save the bag.
4. Slide new filter cartridge into cabinet with "AIR-FLOW" arrow pointing in the direction of airflow.
5. Replace door and place used filter in plastic bag for easy disposal.

	Accu-Fit Model	Filter Size in Inches (Height x Width x Depth)	MERV 8 Filter Part No.	Filters per Carton
Air Handlers	17 ½ x 21	17.25 x 20.75 x 5.00	266944-12117	2
	21 x 21	20.75 x 20.75 x 5.00	266944-12121	
	24 ½ x 21	24.25 x 20.75 x 5.00	266944-12124	
	17 ½ x 28	17.25 x 27.75 x 5.00	266944-12817	
Gas Furnaces	21 x 28	20.75 x 27.75 x 5.00	266944-12821	
	24 ½ x 28	24.16 x 27.75 x 5.00	266944-12824	

MEDIA AIR CLEANER LIMITED LIFETIME WARRANTY

This limited warranty covers TRION residential type media air cleaners, excluding door latch, disposable media cartridge, charcoal filter, accessories, ductwork, and installation. TRION warrants that all new TRION media residential air cleaners are free from defects in material and workmanship under normal, noncommercial use and service. TRION will remedy any such defects if they appear after installation from an Authorized TRION Dealer, subject to terms and conditions of this Limited Lifetime Warranty stated below:

1. THIS LIMITED LIFETIME WARRANTY IS GRANTED BY TRION, 101 MCNEILL ROAD, SANFORD, NC 27330.
2. This warranty shall extend only to any noncommercial owner who has purchased the residential media air cleaner other than for purposes of resale.
3. All components are covered by this limited warranty except expendable items such as charcoal filters and filter cartridges.
4. If within the warranty period, any TRION residential media air cleaner unit or component requires service, it must be performed by a competent heating and/or air conditioning contractor.
5. In order to obtain the benefits of this limited lifetime warranty, the owner must notify the dealer or distributor in writing or by phone, of any defect within 30 days of its discovery. If after reasonable time you have not received an adequate response from the dealer or distributor, notify in writing, by phone, or email: TRION, 101 McNeill Road, Sanford, NC 27330 / 1-800-884-0002 / customerservice@trioniaq.com.
6. This limited warranty does not apply to any part or component that is damaged in transit or when handling, has been subject to misuse, neglect or accident, has not been installed, operated and serviced according to TRION's instruction, has been operated beyond the factory rated capacity, or altered in any such way that its performance is affected. There is no warranty due to neglect, alteration, or ordinary wear and tear. TRION's liability is limited to the replacement of defective parts or components and does not include the payment of labor charges to remove or replace such defective parts.
7. TRION WILL NOT BE RESPONSIBLE FOR LOSS OF USE OF ANY PRODUCT, LOSS OF TIME, INCONVENIENCE, OR ANY OTHER INDIRECT, INCIDENTAL OR CONSEQUENTIAL DAMAGES WITH RESPECT TO PERSON OR PROPERTY, WHETHER AS A RESULT OF BREACH OF WARRANTY, NEGLIGENCE OR OTHERWISE. SOME STATES DO NOT ALLOW THE EXCLUSION OR LIMITATION OF INCIDENTAL OR CONSEQUENTIAL DAMAGES, SO THE LIMITATION OR EXCLUSION IN THE PRECEDING SENTENCE MAY NOT APPLY TO YOU.
8. THIS WARRANTY GIVES YOU SPECIFIC RIGHTS, AND YOU MAY ALSO HAVE OTHER RIGHTS WHICH VARY FROM STATE TO STATE.
9. TRION reserves the right to make changes in the design and material of its products without incurring any obligation to incorporate such changes in units manufactured before the effective date of such a change.



TRION®

101 McNeill Rd. | Sanford, NC 27330

P: 800.884.0002 | F: 800.458.2379 | www.trioniaq.com | customerservice@trioniaq.com