

### Humidifier Limited Two Year Warranty

This limited warranty covers Herrmidifier Residential Type Humidifiers, excluding duct work, wiring and installation. Herrmidifier warrants that all new Herrmidifier Humidifiers are free from defects in material and workmanship under normal, non-commercial use and service. Herrmidifier will remedy any covered defects if they appear within 24 months from the date of original installation as evidenced by receipt of the warranty registration card, subject to the terms and conditions of this Limited Two-Year Warranty stated below:

1. THIS LIMITED TWO-YEAR WARRANTY is granted by Trion Customer Service, 101 McNeill Road, Sanford, NC 27330.
2. This warranty shall extend only to any non-commercial owner who has purchased the residential electronic air cleaner or humidifier other than for purposes of resale.
3. The completion and return of the Warranty Registration Card is a condition precedent to warranty coverage and performance.
4. All components are covered by this limited warranty except expendable items, such as evaporative pads, media filter pads and nozzles.
5. If, within the warranty period, any Herrmidifier residential humidifier unit or component requires service it must be performed by a competent heating and/or air conditioning contractor (preferably the installing contractor). Herrmidifier will not pay shipping charges, or labor charges to remove or replace such defective parts or components. If the part or component is found by inspection to contain such defective material and workmanship it will be either repaired or exchanged free of charge at Herrmidifier's option, and returned freight collect.
6. In order to obtain the benefits of this limited two-year warranty, the owner must notify the dealer or distributor of any defect within 30 days of its discovery. If after reasonable time you have not received an adequate response from the dealer or distributor, notify in writing **Trion Customer Service, 101 McNeill Road, Sanford, NC 27330, or call 1-800-884-0002 or email customerservice@trioninc.com** Humidifiers which have been installed or become part of real estate cannot be returned. Herrmidifier will receive, freight prepaid, only removable parts or components of such defective humidifiers.
7. This limited warranty does not apply to any part or component that is damaged in transit or in handling, has been subject to misuse, neglect or accident; has not been installed, operated and serviced according to Herrmidifier's instructions; has been operated beyond the factory rated capacity; or altered in any such way that its performance is affected. There is no warranty due to neglect, alteration or ordinary wear and tear. Herrmidifier's liability is limited to replacement of defective parts or components and does not include the payment of the cost of labor charges to remove or replace such defective components or parts.
8. Herrmidifier will not be responsible for loss of use of any product; loss of time, inconvenience, or any other indirect, incidental or consequential damages with respect to person or property, whether as a result of breach of warranty, neglect or otherwise. SOME STATES DO NOT ALLOW THE EXCLUSION OR LIMITATION OF INCIDENTAL OR CONSEQUENTIAL DAMAGES, SO THE LIMITATION OR EXCLUSION IN THE PRECEDING SENTENCE MAY NOT APPLY TO YOU.
9. THIS WARRANTY GIVES YOU SPECIFIC RIGHTS, AND YOU MAY ALSO HAVE OTHER RIGHTS WHICH VARY FROM STATE TO STATE.
10. Any warranty by CareCo of merchantability, fitness for use or any other warranty (express, implied or statutory), representation or guarantee other than those set forth herein, shall expire at the expiration date of this express limited warranty. SOME STATES DO NOT ALLOW LIMITATIONS ON HOW LONG AN IMPLIED WARRANTY LASTS, SO THE LIMITATION IN THE PRECEDING SENTENCE MAY NOT APPLY TO YOU.
11. Herrmidifier reserves the right to make changes in the design and material of its products without incurring any obligation to incorporate such changes in units completed on the effective date of such change.

Trion® | 101 McNeill Road | Sanford, NC 27330

Phone: 800-884-0002 | Fax: 800-458-2379

Web: [www.trioninc.com](http://www.trioninc.com) | Email: [customerservice@trioninc.com](mailto:customerservice@trioninc.com)

## G-100ES Duct Mount Humidifier

### Installation • Operation • Maintenance



#### CAUTION:

**READ INSTALLATION, OPERATION, AND MAINTENANCE INSTRUCTIONS CAREFULLY FOR SAFE OPERATION.**

**EXERCISE EXTREME CAUTION WHEN WORKING WITH ELECTRICITY.**

Introduction .....1  
 Specifications .....2  
 Capacity Selection Guide.....3  
 Operation .....3  
 Installation .....5  
     Mounting Locations .....6  
 Maintenance .....7  
 Troubleshooting .....9  
 Description of Parts .....11  
 Parts List .....12  
 Unit Diagram .....13  
 Warranty.....14

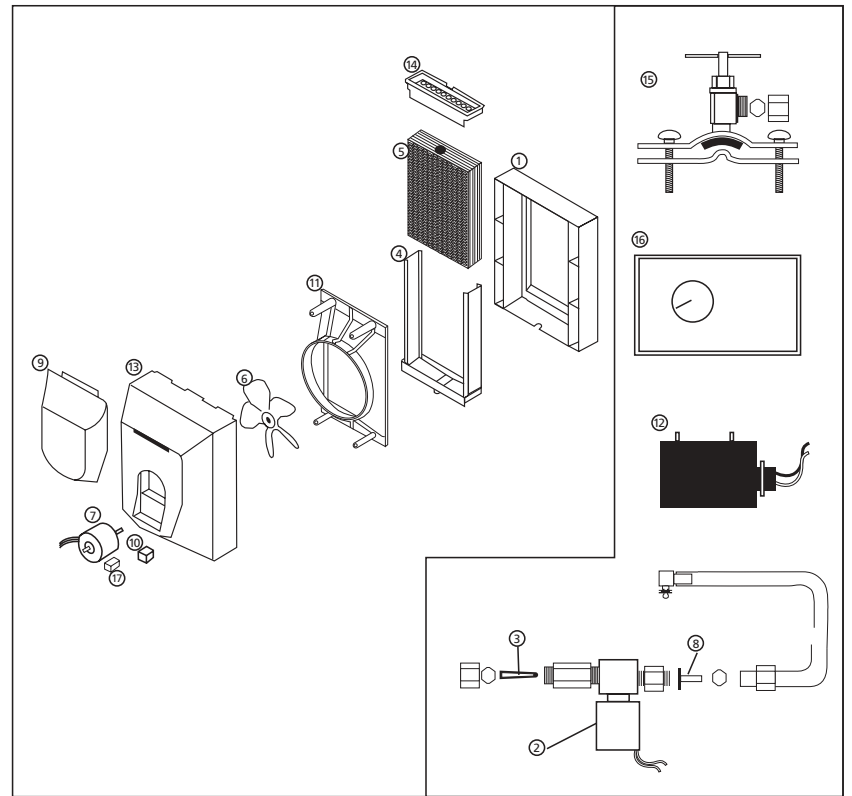

Item	Description	Part Number	Part Number
-	<b>G-100ES Assembly</b>	<b>351453-001</b>	<b>351453-011</b>
1	Base	454275-002	454275-002
2	Brass solenoid valve assembly 24VAC	251461-001	251461-001
3	Replacement cone mesh filters (12 pack only)	G-125-12	G-125-12
4	Drain tray assembly	353226-001	353226-001
5	Replacement evaporator pads (6 pack only)	G-116-6	G-116-6
6	Fan blade 9"	G-110	G-110
7	Fan motor 120VAC	252716-001	-
7a	Fan motor 220-240VAC	-	252716-002
8	Replacement fluid restrictors (12 pack only)	G-128-12	G-128-12
9	Motor cover	454276-002	454276-002
10	Relay 24VAC	G-177	G-177
11	Shroud	454277-002	454277-002
12	Transformer 120VAC/24VAC	G-139	-
12a	Transformer 220-240VAC/24VAC	-	256592-001
13	Unit cover	454274-002	454274-002
14	Water distribution tray	G-105	G-105
15	Saddle valve assembly	IN-2ST	IN-2ST
16	Humidistat	352680-004	352680-004
17	Capacitor 120VAC	257241-001	-
17a	Capacitor 220-240VAC	-	257241-002

**Introduction**

The benefits of a properly humidified environment (35-50%, Relative Humidity) are many. They include both personal comfort as well as the preservation of furniture, draperies, carpets, wooden floors and cabinets, paintings, pianos, etc.. Your home will be more comfortable at a lower temperature (i.e.: 68° F) at 30-40% Relative Humidity (RH) than at 71° to 72° F without controlled humidity. Since every degree of temperature setback represents about 3% of your heating costs, this can possibly represent a significant annual savings.

During the heating season, cold air is brought into the home and heated. When heated, this air dries out and greatly increases its capacity to hold more moisture. By using a humidifier, a source of water is provided to satisfy this increased moisture holding capability, rather than having it drawn from our body surface and the surrounding hygroscopic furnishings in the home.

## Specifications

To improve the efficiency of your humidifier, and to reduce the possibility of a health hazard, it is recommended that you take the following precautions:

- Follow the manufacturer's recommended cleaning and maintenance instructions.
- The amount of minerals and other impurities in a water source can vary greatly, therefore the frequency of cleaning the humidifier also varies.
- During the heating season, check for film or scale build up on the humidifier, evaporator pad, and all moving parts on a monthly basis and establish a proper cleaning schedule.
- Do not allow film or scale to build up on the unit, evaporator pad, or any moving part which will reduce the efficiency of the humidifier.
- At the end of the winter humidification season, drain and thoroughly clean your humidifier as part of the summer shut down. **Be sure to install a new evaporator pad at the beginning of the heating season before starting the humidifier.**

Like your heating system and air conditioning unit, periodic maintenance and cleaning are required to ensure the safe and efficient operation of your humidifier.

### Specifications

Model	G100ES
Type of Unit	Power flow through
Duct mounting	Supply
GPD @ 140°	24.0
GPD @ 120°	19.0
GPD @ 100°	14.5
Solenoid valve voltage	24VAC
Motor	1/20 HP - 120VAC (220-240VAC International)
Unit W x D x H	13" x 11 1/2" x 18 3/4"
Duct Opening W x H	12 1/4" x 15 1/4"
Shipping Weight	18 lbs
Standard Equipment	Wall/Duct Mount Humidistat Self Piercing Saddle Valve 120VAC (220-240VAC International) to 24V Transformer Power Cord with 3-Prong Plug
Features	Brass solenoid valve assembly Removable motor cap allows easy access to motor for servicing or maintenance Cleanable & replaceable internal water filter protects the solenoid valve Attractive design and finish - neutral beige color 2" evaporator pad for greater surface area

## Description of Parts

### Description of Parts

#### Solenoid Valve

All brass construction, controls the flow of water to the humidifier. The solenoid valve will make a clicking sound as the plunger pin opens and closes. If this part fails to operate correctly, water will flow continuously through the humidifier and down the drain.

#### Conical Mesh Filter

Traps small particles in water supply that can clog and damage the solenoid valve. Must be cleaned or replaced when water flow is impeded or humidification is reduced.

#### Evaporator Pad

Allows water to evaporate as warm, dry air is drawn through it. Must be replaced on a regular basis to maintain efficiency.

#### Fluid Restrictor

Located within the water tubing of the humidifier, it controls the amount of water that flows through the humidifier.

#### Water Distribution Tray

Felt wicking allows even distribution of water across surface of evaporator pad. As mineral deposits build up, the tray will effectively channel the water through the evaporator pad. Holes in tray must be cleaned periodically.

## Troubleshooting Guide

Symptom	Possible causes	Corrective Action
Humidity level is not being maintained	Evaporator pad is clogged with mineral deposits	Replace the evaporator pad
	Water line is clogged with mineral deposits or debris	Clean or replace conical mesh filter and fluid restrictor
	Humidistat setting is too low	Increase the humidity setting on the humidistat
	Saddle Valve is not fully open	Turn the saddle valve handle in a counterclockwise direction until it stops
	Evaporator pad is upside down	Make sure the evaporator pad is installed with the black mark up
Humidifier will not turn on	Home is not tightly insulated	Seal leaks or drafts around doors and windows Increase the humidistat setting (this will only help, not solve the problem)
	Humidistat level is too low	Increase the humidity setting on the humidistat
Water flows through the humidifier constantly	Solenoid valve is clogged or broken	Contact dealer for service or replacement
	Solenoid valve is stuck in the open position	Clean the solenoid valve Contact dealer for service or replacement
Rust is developing around the humidifier	Air pressure velocity through the evaporator pad is too high	Contact dealer for possible solutions
	Leak in the water fill tube located in the base	Check the fill line for leaks Contact dealer for service or replacement

Trion® | 101 McNeill Road | Sanford, NC 27330

Phone: 800-884-0002 | Fax: 800-458-2379

Web: [www.trioninc.com](http://www.trioninc.com) | Email: [customerservice@trioninc.com](mailto:customerservice@trioninc.com)

## Air Tightness of Home

Sq. Footage of Home	Tight Home (GPD)	Average Home (GPD)	Loose Home (GPD)
1000	0.5	5.0	10.0
1500	3.0	10.0	16.5
2000	5.0	14.0	24.0
2500	7.5	19.0	30.5
3000	10.0	23.5	37.5
4000	14.5	33.0	51.5

The above calculations are for reference only and are based on the following

- Inside temperature 70° F/35% Relative Humidity
- Outside Temp 20° F /70% Relative Humidity
- 8 foot ceiling height
- Internal moisture gain of one pound per hour
- Furnace on-time of 70%

This chart uses A.R.I. standard designations:

A "Tight Home" is assumed to be well insulated with vapor barriers, tight storm windows and doors, and a dampered fireplace. Air exchange rate of .5 changes per hour.

An "Average Home" is insulated and has a dampered fire place, but there are no vapor barriers, storm doors, or storm windows. Air exchange rate of 1.0 change per hour.

A "Loose Home" is generally one constructed before 1930, has little or no insulation, no storm doors, storm windows, weather stripping or vapor barriers, and often no effective dampering of fireplaces. Air exchange rate is as high as 1.5 changes per hour.

## Operation

This humidifier operates using the evaporative principle in a quiet, efficient and automatic manner. It is constructed of the highest quality, engineering grade materials to assure superior performance and durability. This humidifier is controlled so that it operates only when the furnace blower is operating and the humidistat, which is installed on the cold air return duct or in your living area, calls for humidity.

When there is a call for humidity and the circulating air blower is operating, the solenoid valve opens and water flows into the distribution tray and trickles down through the evaporator pad. Warm, dry air is drawn through the evaporator pad, where it absorbs moisture and is returned to the duct, and is circulated throughout the house. There is no standing water in this humidifier, thus reducing maintenance and handling. The drain, located at the bottom of the unit, allows unused water to drain from the humidifier and flush away mineral deposits that have been left behind after the evaporation process. A fluid restrictor located in the evaporator pad supply tubing controls the amount of water flowing through the humidifier.

**Do NOT attempt to control the flow of water by using the saddle valve. It is designed to be either fully open or closed.**

A felt pad located in the distribution tray distributes water evenly between the openings. The distribution tray should be inspected annually and any plugged holes cleaned (more frequently in areas of poor water quality).

**Start Up**

1. Open the saddle valve and check for leaks at the connections.
2. Turn the furnace on and check for proper operation.
3. Turn the humidistat to the highest level (past 60%) and the humidifier should begin to operate (the humidifier should stop when the humidistat is turned off, or when the furnace blower shuts off).
4. Set the furnace controls and humidistat for the desired conditions. 30-40% Relative Humidity is typically recommended, but it is important to reduce the setting whenever extreme low outdoor temperatures occur in order to avoid excessive condensation. The settings noted in the relative humidity table represent the best compromise for both comfort and protection of home furnishings. Condensation of water on the inside windows is usually an indication of too high relative humidity.

Recommended Relative Humidity Levels vs. Temperature	
Outside Temperature (°F)	Recommended Relative Humidity %
40	45
30	40
20	35
10	30
0	25

**Common Questions & Answers**

**Q. My humidity is too low. Why isn't the humidifier working?**

A. This is one of the most common questions from homeowners with new humidifiers. There are many factors that decide how well a home will be humidified. The primary factors are the size of the home and how well it is insulated (assuming the humidifier is installed properly). The issue could range from something as simple as the humidistat setting not being set high enough to a complex situation involving the home environment and material construction. New cabinets, wood floors and furniture have the tendency to absorb moisture quickly. These wood materials will continue to absorb moisture until their saturation point is reached. In addition, doors that open and close often will allow the internal humidity to escape into the outdoors. The size of crawlspaces, such as attics and dead spaces in construction will also affect how well the living space is humidified. If you have concerns or questions about the operation of the humidifier, consult your dealer for an on-site inspection and analysis.

**Q. The humidifier is running all the time. Is this normal?**

A. The humidistat may be broken or your home may have a high transfer of air. Drafts and leaky construction will allow the humidity to expand to fill whatever space it is in. If your home is not sealed tightly, the humidity will escape into the outside air, wasting your electricity and water. Another cause could be an improper electrical installation. The humidifier is designed to be used in conjunction with the furnace blower.

**Q. Water is constantly flowing out the humidifier drain and I am afraid that it is wasting water. Should I be concerned?**

A. Flow-thru humidifiers are designed to use the action of flowing water to continuously flush minerals and debris from the evaporator pad when the HVAC system is running and there is a demand for additional humidity, thus increasing their useful life expectancy and resulting in fewer maintenance needs. However, if the water usage is constant and does not appear to cycle with the HVAC system turning ON and OFF, servicing may be necessary.

**Q. Where do I get the parts that must be replaced on a regular basis?**

A. Your dealer can help supply you with the parts you need.

**Q. I do not need my humidifier on all year round. What do I do during the summer months?**

A. First, turn the saddle valve to the OFF position. In some installations, a damper will be installed on the ductwork that will allow you to shut off the air from the regular HVAC system. This damper will keep cooler air from flowing into the humidifier and wasting electricity.

**Q. How do I control the humidifier and the level of humidity in my home?**

A. The humidistat is the only way the humidifier understands how much humidity is in the air. A nylon element in the humidistat expands and contracts as the humidity level changes and this movement signals the unit to turn ON and OFF.

If you have questions not answered here, please contact:

Trion® | 101 McNeill Road | Sanford, NC 27330  
 Phone: 800-884-0002 | Fax: 800-458-2379  
 Web: [www.trioninc.com](http://www.trioninc.com) | Email: [customerservice@trioninc.com](mailto:customerservice@trioninc.com)

### To Inspect and Replace the Evaporator Pad:

It is recommended that the evaporator pad in the humidifier be replaced annually to maintain efficient operation. However, more frequent replacement may be necessary in areas of poor water quality.

1. Disconnect the power supply to the furnace. Turn OFF the water supply at the saddle valve by turning the valve handle clockwise.
2. Fully loosen the thumb screws at the bottom of the unit cover. The screws will remain attached to the cover. To remove the cover from the duct, pull the bottom away and then lift up. Put the cover aside for reassembly.
3. Remove the water distribution tray, located above the evaporator pad. It is held in place by a snap that must be lifted to pull out the tray.
4. Pull the evaporator pad and frame assembly away from the duct, being careful not to disturb the drain connection. Remove the old evaporator pad and discard.
5. Inspect the interior of the humidifier and remove any mineral deposits and accumulation from the frame assembly and drain tray.
6. Remove the new evaporator pad from the plastic bag and insert into the frame assembly, **with the black spot facing up**. Ensure that no part of the evaporator pad is outside of the frame. Return the evaporator pad and frame assembly to their original position inside the humidifier.
7. Check the distribution tray to ensure that holes are clear of any scale build up. If desired, the distribution tray can be washed with mild detergent and warm water.
8. Replace the distribution tray making sure the snap is hooked over the outside edge of the tray. Replace the cover and secure by tightening the thumb screws. Turn the water back on and reconnect power to the furnace.

### End of Heating Season Shut Down:

1. Inspect and clean humidifier and components.
2. Turn water supply off at the solenoid valve.
3. Turn humidistat off.

### See installation instructions on the provided mounting template

Read the instructions in the furnace installation manual carefully before attempting installation or operation of the humidifier. Failure to follow these instructions may result in improper installation and therefore, void the manufacturer's warranty.

### WARNING

**Improper electrical wiring can cause personal injury, death, or property damage. Local codes require that the unit be installed by a properly qualified HVAC technician or electrician.**

Some furnaces provide 120VAC (220-240VAC International) auxiliary terminals that may be used to power the humidifier. Since these auxiliary terminals are interlocked with the fan, no separate fan interlock relay is required in the humidistat circuit depending on the furnace model. These terminals are marked HTG.Acc/Neutrals. Acc/Neutral or Hum-H/Hum-N.

When connected to these furnaces using the auxiliary terminals interlocked to the furnace fan, connect the primary of the supplied 120VAC (220-240VAC International) to 24VAC transformer to the auxiliary terminals on the furnace. Connect the secondary of the transformer to the unit pigtailed on the SPST humidistat provided. The humidifier will then turn on whenever the furnace fan is running and there is a call for humidity.

For systems without 120VAC (220-240VAC International) or 24VAC auxiliary terminals or systems with multi-speed blowers, the switch contacts of a separate SPST-NO fan interlock relay is required to be wired in series with the humidistat switch. Depending on the installation and furnace manufacturer the coil for this relay could be:

- Wired in parallel with the coil of the NO fan relay, typically 24VAC.
- Wired in parallel with the common and heating speed tap of the units blower typically 120VAC or 240VAC.
- An inductively coupled current sensing relay on the common of the units blower.

## Mounting Locations

1. This humidifier may be installed on either the supply or return plenum.

The supply plenum is the preferred location because of higher evaporative capacity results. When there is insufficient space on the warm air plenum, the unit can be installed on the return duct. It is recommended that when the unit is installed in this location it is supplied with hot water service.

2. If the furnace has an air conditioning coil, be sure the unit does not interfere with coil ends.
3. Remember to provide clearance for evaporator pad removal, conical mesh filter cleaning, and fluid restrictor cleaning.

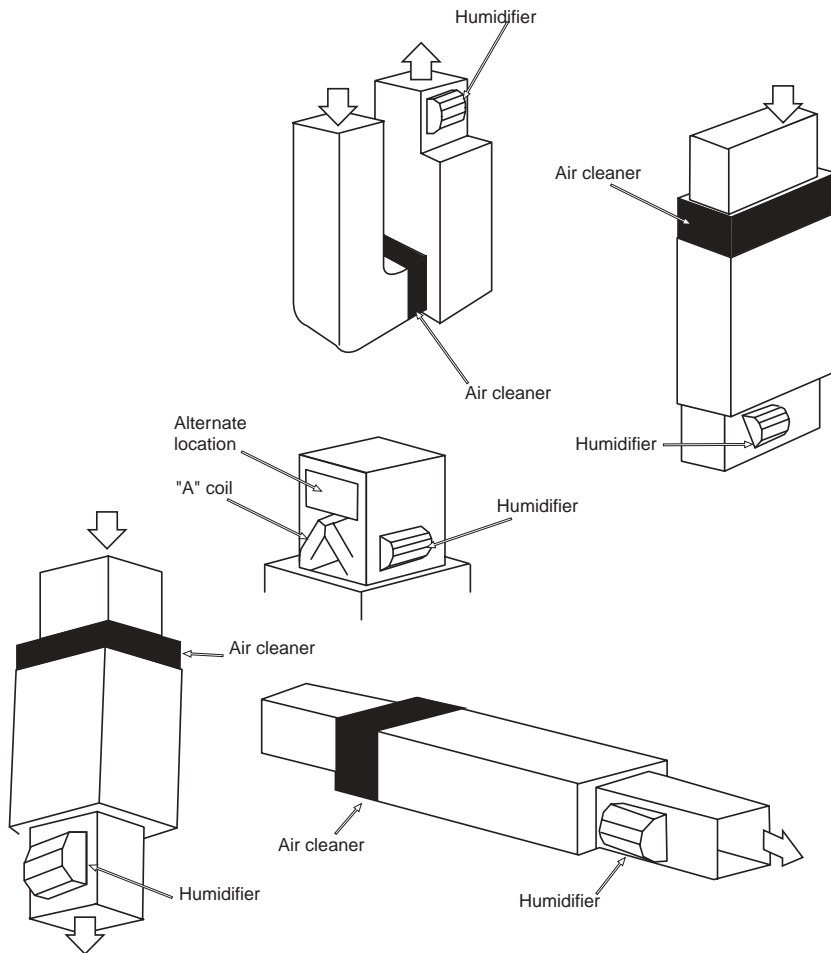

## Maintenance

### Maintenance of Your Humidifier

Your humidifier, as all appliances, requires periodic cleaning and maintenance to ensure efficient and safe operation. The necessity to clean your humidifier is substantially the result of impurities coming in through your water supply, which feeds the humidifier. Other household dust, containing biological and microbial contaminants, finds its way into the air handling system and ultimately, the humidifier. The humidifier is not the source of these impurities.

To enjoy the benefits of a properly humidified environment, periodic cleaning is necessary to control both water and household impurities. Film or scum, which can contain bacteria or fungi, may appear on the water surface, the sides, or bottom of your humidifier. A crusty deposit or scale may also appear and is composed of minerals that have settled out of the water.

Annual cleaning is required for the efficient and safe operation of this humidifier. However, more frequent maintenance and cleaning may be required in areas of poor water quality. During the first heating season, check for scale buildup on a monthly basis and establish the proper cleaning schedule. Failure to do so can result in reduced efficiency and/or water damage to house and property. If frequent cleaning of the humidifier is required, a sediment filter should be installed upstream of the conical mesh filter to reduce the frequency of cleaning. Water softeners can be used to improve the quality of the supply water, however, deionized water is corrosive and can reduce the operating life of your unit.

### To Inspect and Clean the Conical Mesh Water Filter

1. Turn OFF the water supply at the saddle valve by turning the valve handle clockwise.
  2. Disconnect the water line from the INLET fitting of the solenoid valve using two (2) wrenches, one for the compression nut and one on the INLET fitting.
  3. Remove the conical mesh filter from inside the inlet fitting using a small nail or paper clip.
- NOTE: Be careful not to puncture the filter.**
4. Clean or replace the filter as needed.
  5. Replace the filter and reconnect the water line to the INLET fitting reversing the directions in Step 2.
  6. Turn the water back ON at the saddle valve.

### To Inspect and Clean the Fluid Restrictor

1. Turn OFF the water supply at the saddle valve by turning the valve handle clockwise.
  2. Disconnect the water line from the OUTLET fitting of the solenoid valve using two (2) wrenches, one for the compression nut and one on the OUTLET fitting.
  3. Locate the fluid restrictor, inside the end of the water line, and inspect it for sediment clogging and accumulation. Clean or replace fluid restrictor as needed.
- NOTE: Do NOT attempt to enlarge the hole size in the restrictor.**
4. Reconnect the water line to the OUTLET fitting reversing the directions in Step 2.
  5. Turn the water back ON at the saddle valve.